

CONTENTS

	Page
Receiving Procedures.	1
Warranty.	1
Safety Information.	1 - 2
Machine Description.	3
Installation /Assembly Instructions.....	4
Operating Instructions.	4
Maintenance.	4

Operator’s Manual
for Morse Mobile-Karrier / Palletizer

Model 82A
Serial Number 0218 to ____ (MMYY)

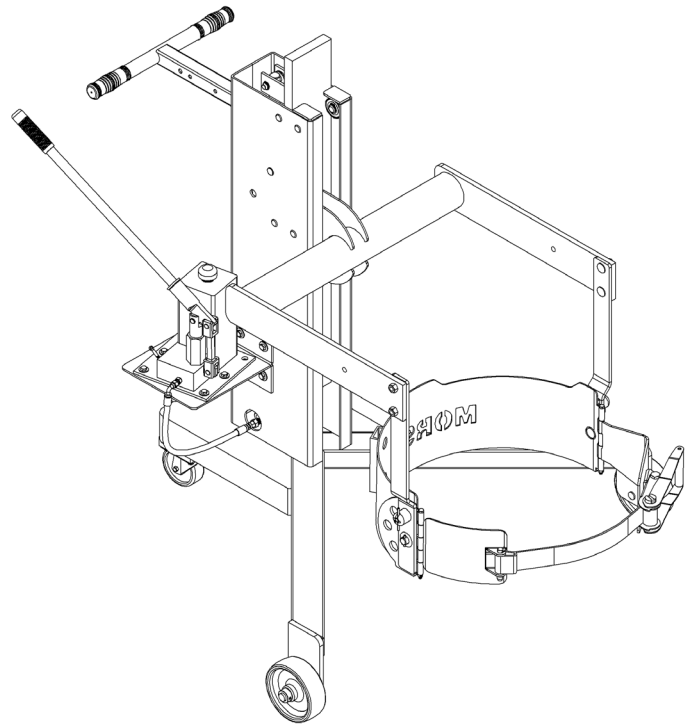

Receiving Procedures

Every Morse drum handler is inspected prior to shipping. However, damage may be incurred during transit.

- Check for visible damage. If you choose to accept damaged freight, always sign noting the damage on the **Bill of Lading**.
- Document the damage and have the truck driver sign. We recommend keeping a digital camera at your receiving dock for this purpose.
- Open packages expeditiously to check the condition of the goods. There is only a 24 hour window to notify the carrier of any concealed damage.
- Immediately **report all damage to the shipping company!** Then you may contact Morse for assistance with your freight claim.
- Morse Manufacturing will not be held responsible for any damaged freight that is not signed for as damaged.

Limited 2 Year Warranty

Morse drum handling equipment is guaranteed against defects in workmanship or materials for two years when used properly within its rated capacity. Warranty does not cover wear from normal use or damage from accident or abuse. Motors and other purchased parts carry the warranties of their manufacturers.

For warranty claims, contact your Morse Dealer to obtain a return authorization number, and for return freight advice. Return freight must be prepaid.

In all instances, liability is limited to the purchase price paid or to repairing or replacing the product. Customer assumes liability for any modifications, unauthorized repairs or parts substitution.

Safety Information

While Morse Manufacturing Co. drum handling equipment is engineered for safety and efficiency, a high degree of responsibility must be placed upon the machine operator to follow safe practices, based primarily on common sense, upon which true safety depends.

Failure to follow the safety precautions in this manual can result in personal injury or property damage. Observe the same precautions as with similar machinery where carelessness in operating or maintenance is hazardous to personnel. Carefully read the safety precautions below and throughout this manual.

Review the Material Safety Data Sheet(s) for the material(s) in the drum(s) and take all necessary precautions. Safety shoes, work gloves, hard hat and other personal protective devices are recommended.

Prior to initial use, inspect all moving parts. Inspect saddle assembly for proper operation. Perform necessary load test, inspections, operator training, etc.

Operator's Manual for Model 82A Morse Mobile-Karrier / Palletizer Serial Number 0218 to ____ (MMYY)

Safety Information (continued)



DANGER - Indicates a situation which, if not avoided, will result in serious injury or death. This signal word is limited to the most extreme situations.



WARNING - Indicates a situation which, if not avoided, could result in serious injury or death.



CAUTION - Indicates a situation which, if not avoided, can result in damage to the machine.



CAUTION – Do Not Transport with Drum Raised. Always lower the drum holder to lowest position before transporting.



WARNING - The Mobile-Karrier / Palletizer is designed to handle one drum of the types listed at the top of page 3. Machine Description. DO NOT attempt to handle any other type of drum or object. DO NOT exceed the weight capacity of 600 Lb. (272 kg).



WARNING - Level Floors Only

For operation only on clean, level floors of suitable bearing capacity. Do not use on sloped surfaces, ramps, irregular or debris strewn floors.



WARNING - Do Not Modify the Unit. Under no circumstances should any modifications be made to the Morse machinery without factory authorization. Any modifications may void the warranty. This machine was designed to perform a specific job and alterations may result in injury to operator or machine.



WARNING - No Loose Fitting Clothing. Wear close-fitting clothing and safety equipment appropriate to the job. Loose fitting clothing may become caught on the machinery and cause severe personal injury.



WARNING - Hydraulic Fluid Under Pressure Can Be Hazardous

Escaping hydraulic fluid under pressure can penetrate the skin, causing serious injury. Avoid the hazard by relieving pressure before disconnecting hydraulic lines. Keep hands and body away from pinholes and nozzles, which eject fluid under high pressure. Use a piece of cardboard to search for leaks. If an accident occurs, see a doctor immediately and inform them of the nature of the accident.



CAUTION - Wear safety shoes with non-slip soles and hard toe protection.



CAUTION - DO NOT allow drum to impact on floor, ground, or dumping station, etc.



WARNING: This product can expose you to chemicals including barium sulfate, cobalt, titanium dioxide, and 2-methylimidazole, which are known to the State of California to cause cancer, and bisphenol-A, which is known to the State of California to cause birth defects or other reproductive harm.

For more information go to www.P65Warnings.ca.gov

Operator's Manual for Model 82A Morse Mobile-Karrier / Palletizer
Serial Number 0218 to ____ (MMYY)

Machine Description

The Mobile-Karrier / Palletizer is designed to lift, transport, and dispense a ribbed 55-gallon (210 liter) steel drum with 22.5" (57.2 cm) diameter. The maximum capacity is 600 Lb. (272 kg).



Options

- A smaller diameter drum can be handled with the correct size 55/30 Series Diameter Adaptor installed (see [Diameter Adaptor literature](#)).
- The **Bracket Assembly** (Part # 4556-P) is **required** to handle a plastic or fiber drum without a top rim (see figure 2.1). You can use the Bracket Assembly with a 55-gallon (210 liter) plastic, steel or fiber drum. The brace at top and bottom of the drum prevent it from slipping lengthways through the drum holder. It adjusts for a drum 31" to 39" (79 to 99 cm) tall.
- The **Top Rim Clamp** (Part # 4560-P) grips the upper rim of your drum to prevent it from slipping through the drum holder (see figure 2.2). To handle a 55-gallon (210 liter) plastic or fiber drum with top rim, you **must** install either the Bracket Assembly or the Top Rim Clamp. You can use the Top Rim Clamp with a 55-gallon plastic, steel or fiber drum with suitable top rim.

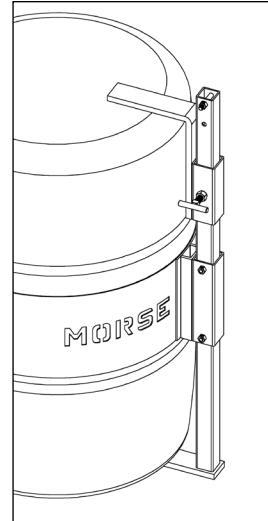

Figure 2.1
Plastic drum being lifted with part number 4556-P Bracket Assembly installed.

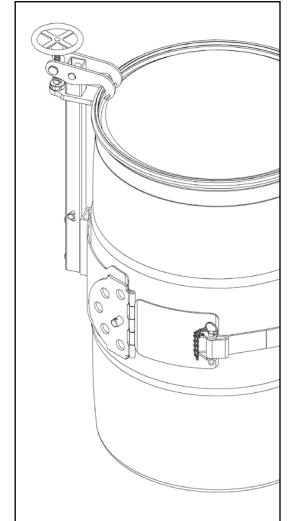

Figure 2.2
Plastic drum being lifted with part number 4560-P Top Rim Clamp Assembly installed.

Controls

The Morse Mobile Karrier / Palletizer is manually propelled and steered.

There are two functions for the operator to control:

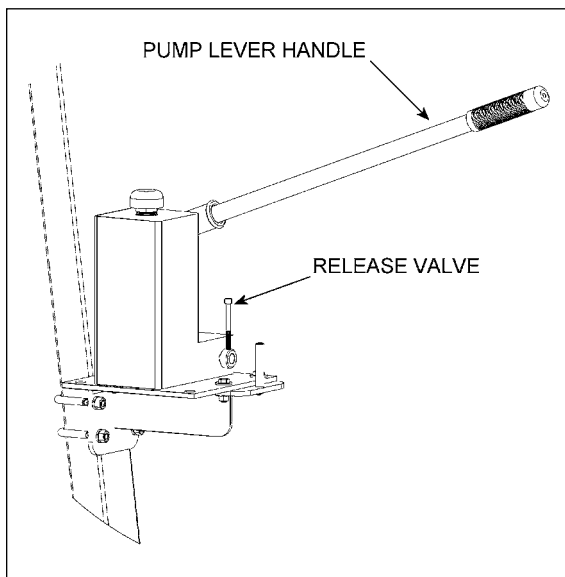

Figure 2.3

1. "LIFT" and lower function for vertical positioning of the drum
2. "TILT" function to control the degree of rotation of the drum

LIFT and Lower Function (Figure 2.3)

To raise the drum

1. Insert pump lever handle into pump socket.
2. With the release valve closed, begin to pump the lever handle. The drum will lift.

To lower the drum

Open the release valve slowly, a part of a turn. Allow the drum to descend at a controlled rate. The valve may be reclosed to hold the drum at any height.

TILT Function

To tilt the drum

1. Either one of the two spring loaded plunger tilt-locks may be locked to hold the drum upright. It is not necessary to lock both of them.
2. Position drum at pouring station.
3. Before unlocking the tilt-lock(s) to permit tilting the drum, it is recommended that you steady the drum and be prepared for its possible tendency to tilt toward its heavier side.
4. With both tilt-locks unlocked, manually tilt the drum for pouring. The drum pouring angle may be varied or it can be locked in various positions by one of the tilt-locks.



WARNING: Keep hands and fingers clear of tilt lock hole, as a pinch point will occur when drum rotates.

Operator's Manual for Model 82A Morse Mobile-Karrier / Palletizer
Serial Number 0218 to ____ (MMYY)

- - IMPORTANT - -

Installation / Assembly Instructions

Machine is shipped with hydraulic fluid.

BEFORE operation, REMOVE the **RED** shipping plug from the hydraulic reservoir. REPLACE with supplied **BLACK** breather.

Insert pump handle into pump socket.

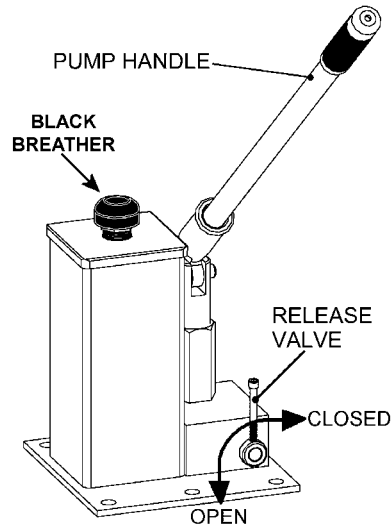

Operating Instructions

1. Roll drum lifter to drum. Steer unit so drum holder meets middle of drum (Figure 4.1). Operate hydraulics as necessary. Swing both hinged bands to the open position. Roll the unit forward and push drum holder so that drum holder (saddle) will encircle drum.

WARNING: Keep hands and other objects away from top opening of lifting frame.

2. To secure drum: Drape web strap across face of drum, thread strap through slot in ratchet. Operate ratchet to tighten strap around drum (Figure 4.3).
3. Operate lift function to raise drum off the floor, push drum lifter to deliver drum. Avoid unreasonably rough or non-level surfaces. Move at moderate speed. Carry drum only high enough to avoid contact with the floor or obstacles. Push loaded unit when possible for transporting. Pulling unit should be limited to maneuvering at short distance.

4. Either one of the two spring loaded plunger tilt locks (Figure 4.4) may be locked to hold drum upright. Unlocking both will permit drum to be tilted. Drum pouring angle may be varied or drum can be locked in various positions by inserting one tilt lock. It is not necessary to lock both tilt locks. Before unlocking tilt lock it is recommended that you steady drum and prepare to resist its tendency to tilt toward its heavy end.

WARNING: Keep hands and fingers clear of tilt lock holes, as a pinch point will occur when drum rotates.

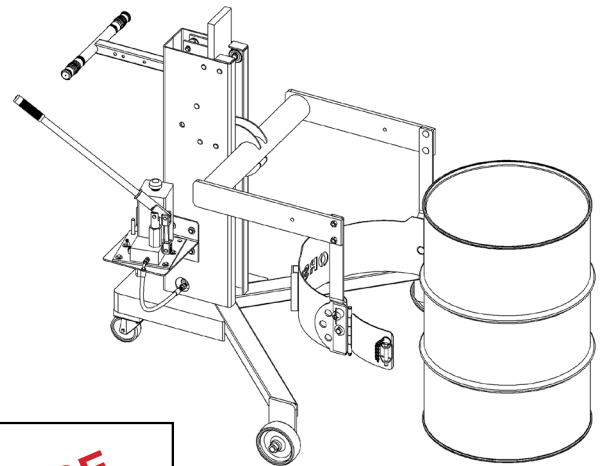

Figure 4.1



Figure 4.2



Figure 4.3



Figure 4.4

Operator's Manual for Model 82A Morse Mobile-Karrier / Palletizer
Serial Number 0218 to ____ (MMYY)

5. With tilt-locks unlocked, manually tilt the drum for pouring (Figure 4.5). The drum pouring angle may be varied or it can be locked in various positions by one of the tilt-locks.
6. After emptying, rotate drum back to vertical position and lower.
7. Before unloading drum, release tilt locks and return drum to upright. Lower drum at a controlled rate.
8. To remove drum: Squeeze the ratchet release lever and open all the way to unlock. Then release the tension on the strap. Allow enough slack in order to remove strap loop from clevis. Swing both hinged bands to open position. Pull unit away and park on level floor, out of traffic lanes when not in use.
9. Adjustment for Shorter Drums: The drum holder assembly is factory set in position for handling typical 55-gallon (210 liter) drums. For handling shorter drums such as typical 30-gallon (114 liter) drums, relocate drum holder assembly downward as follows: Detach by removing nuts that hold it to lifting assembly. Reattach at alternate location 6" lower.

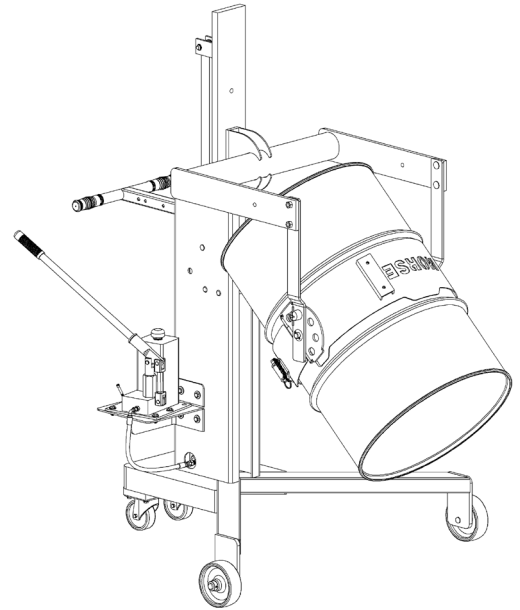

Figure 4.5

Maintenance

Periodic inspection for the general condition of structural and mechanical components is imperative for safe and efficient operation.

- Periodically inspect all moving parts, framework, and contact areas for signs of wear, fatigue, or loosening. Tighten, adjust, or replace parts as necessary to prevent failure and maintain proper function.
- Inspect the hydraulic system for oil drips, hose damage, or other signs of wear. Inspect the level and condition of the hydraulic fluid. Replace any parts that show signs of wear.
- Grease wheel bearings periodically. Oil or grease all moving parts including: Tilt locks, fulcrum shafts, hinge pins, and the ratchet.
- Worn or damaged parts must be properly replaced with the correct, genuine Morse parts.
- Hydraulic pump is shipped filled with Noco Premium plus automatic transmission fluid d/m. Material safety data sheet (msds) is available online. Change oil yearly, sooner depending on dirty conditions or outdoor use. Replace oil with Mobil dte 24 or equivalent for indoor use (Mobil dte 13 for outdoor use).
- The web strap should be removed from service or replaced if any of the following are visible:
 - Acid or caustic burns
 - Melting or charring of any part of the strap
 - Holes, tears, cuts, snags or embedded articles
 - Broken or worn stitching in load bearing splices
 - Excessive abrasive wear